



**Championship Auto Racing Series  
Super Late Model Tour Rules**

**136 Bridle Path Lane  
 Mooresville, NC 28117  
 704-662-9212 PH  
 704-662-9207 FAX**

**[www.carsracingtour.com](http://www.carsracingtour.com)**

---

**UPDATED 12/16/19**

**RULE BOOK DISCLAIMER**

The rules and regulations set forth herein are designed to provide for the orderly conduct of racing events and to establish minimum acceptable requirements for such events. These rules shall govern the condition of all events, and by participating in these events, all participants are deemed to have complied with these rules.

NO EXPRESSED OR IMPLIED WARRANTY OF SAFETY SHALL RESULT FROM PUBLICATIONS OF/OR COMPLIANCE WITH THESE RULES AND/OR REGULATIONS. They are intended as a guide for the conduct of the sport and are in no way a guarantee against injury or death to a participant, spectator, or official.

By signing in at each event, all persons agree to unconditionally abide by the rules and regulations as set forth in the CARS Super Late Model Tour Rules and Regulations---2020.

CARS shall be empowered to permit reasonable and appropriate deviation from any of the specifications herein or impose any further requirements.

Any interpretation or deviation of these rules is left to the discretion of the CARS Tour Officials. Their decision is final.

Championship Auto Racing Series Management



## NOTICES

1. The Rules and Regulations as set forth herein are designed to provide for the orderly conduct of CARS racing events and to establish minimum acceptable guidelines for such racing events sanctioned by the CARS Tour.
2. The rules herein shall govern the condition of all CARS Tour racing events and all participants are expected to abide by and comply with these rules and regulations.
3. No express or implied warranty of safety shall result from publications of/ or compliance with these or any other CARS Tour rules and regulations, or any CARS Tour directive or ruling by any CARS Tour official.
4. The CARS Tour director shall be empowered to make changes from any specification contained within these rules and regulations. Furthermore, he/she may impose further restrictions that, in his/her opinion, do not alter the minimum accepted standards.
5. No expressed or implied warranty of safety shall result from such alteration of specifications. All such interpretation and deviation is at the sole discretion of CARS Tour officials.
6. Regulations and specifications set forth herein are automatically amended by, but not limited to, technical bulletins and official entry blanks distributed by the Tour.
7. All specifications and regulations contained herein are subject to immediate change -without notice – as determined by the Tour Director.
8. The intent of these Rules and Regulations is to provide for competitive racing in all CARS Tour events.
9. CARS Tour reserves the right to change – without notice – schedule and event purses.
10. These rules are subject to amendment as CARS Tour officials deem necessary.

## DEFINITION OF TERMS

Within these 2020 Rules and Regulations, the following terms are defined as:

1. "Office" shall mean the principal headquarters for the series, located at 136 Bridle Path Lane, Mooresville, NC 28117. Telephone: 704-662-9212.
2. "CARS Tour Officials" shall be employed and supervised by Championship Auto Racing Series.
3. "Member" shall mean all those individuals who have signed in to the "garage/pit/restricted area" at 2020 events.
4. "Event" shall refer to the CARS Tour sanctioned event,

including, but not limited to, practice days and race days.

5. "Promoter" shall refer to such an individual, owner, president, principal, etc. -who represents the track at a CARS Tour sanctioned event.

## GENERAL RULES AND REGISTRATION

The rules listed herein are effective from January 1, 2020 until December 31, 2020. The following rules supersede all previous published rules for any CARS Tour class of racing.

### Series Registration Procedure

1. The annual 2020 team registration will be \$250. This fee is non-refundable.
2. The 2020 annual driver's registration and license will be \$100. This fee is non-refundable.
3. The 2020 single event registration is \$125 for the owner and \$50 for the driver. The single event licenses are good for registered event only and the fee may not be applied to annual registration fees.
4. It is mandatory for all competing drivers and cars to be registered for an event in which they participate.
5. Each team assumes responsibility for notification to CARS Tour of any change in address.
6. Each driver and team owner must complete tour registration forms prior to participation in any CARS event.
7. Car numbers are assigned by CARS Tour on an annual basis. CARS Tour officials will assign numbers after receipt of tour annual registration forms accompanied by the annual registration fee.

## CARS MEMBERSHIP

### General Rules

1. No intoxicating beverages or controlled substances are to be consumed before or during race events by anyone in the pit area. Owners assume full responsibility for actions of their crew members.
2. CARS Tour reserves the right to require alcohol and/or drug test to drivers, crew members, and car owners at any time during the course of any event.
3. Physical or verbal abuse of any CARS Tour official will not be tolerated and is subject to fines and/or suspensions.
4. Race vehicles may only be driven by individuals with a valid annual CARS Tour license. Licenses are NOT TRANSFERABLE.

5. Interpretation of rules, procedures or scoring positions by CARS Tour shall be final, non-appealable, and not litigable.
6. Drivers, owners, and/or any other member of a crew shall have no claims against or cause of actions for damages, expenses, or otherwise against CARS Tour or its officials or promoter by reason of disqualification or damage to either, car, driver, or both.
7. Race cars may be mechanically inspected by CARS Tour officials at any time.
8. Entry fees and pit gate fees shall be non-refundable. Entry fees must be paid prior to pit gate entrance.
9. Purse and owner championship points fund money, if any, will be distributed to owner of car in accordance with the 2020 W-9 form which will be completed by owner. Any changes to distribution of funds will be the owner's responsibility. Proper income tax information, including Federal ID numbers and/or social security numbers, must be on file before funds are distributed.
10. The decision on transporter height -i.e. whether or not trucks will remain in the infield -will be determined on a race by race basis.
11. All rules and regulations in CARS Tour rule book are subject to interpretations by CARS Tour officials.
12. All cars must be ready to qualify at their specified time. Any car not ready for qualifying will be a one (1) lap qualifier. Additionally, any driver or spotter late for the driver/spotter meetings shall also receive a one (1) lap qualifying session. Any driver late for driver introductions and/or autograph session shall be relegated to the rear of the starting field.

## **CARS LICENSES**

### **License for Driver**

1. All drivers must have a current and valid driver's license unless a waiver is obtained from CARS.
2. All drivers must be at least **14 years of age**. No exceptions.
3. All drivers must be physically fit for racing. Tour director reserves right to request medical certification of fitness at his sole and absolute discretion.
4. All new drivers will be monitored by officials and their ability will be continuously evaluated.
5. Owner will be held responsible for actions of all crew members.
6. CARS Tour reserves the right to revoke entry to anyone to any CARS Tour event for "just cause".

## **INSURANCE AND LIABILITY**

### **Insurance**

1. Insurance is made available to participants and/or persons entering the restricted area of a CARS Tour sanctioned event for accidental death or hospital, and/or medical bills. Such insurance is for a period normally associated with the completion of an event and for risks associated with participation in that event. Insurance shall be applied as secondary coverage **ONLY** after participant's primary coverage reaches its limits of coverage.
2. Persons admitted to the pits and other restricted areas of a CARS Tour race must obey all rules and regulations for that area as set forth by CARS Tour. Every individual admitted to any CARS Tour event must sign all releases as determined and/or required by CARS Tour.

### **Waivers**

1. Performance, Advertising & Promotion Release: That CARS Tour and it's assigns may use their name(s), picture (s), likeness(es) and performance(s) in any way, medium or material (including without limitation by and through television, radio, air wave, cable and satellite broadcasts, film productions, videotape and audiotape reproductions, transmission over the internet, video games or other CARS Tour licenses products and public and private online services authorized by CARS Tour and the like), before, during and after the event, for promoting, advertising, recording or reporting the event or any other CARS Tour sanctioned event, and do hereby relinquish all rights thereto for these purposes, provided that the car owner and driver retain exclusive use of its name, picture and likeness in connections with product endorsements and the sale of products, services, concessions, and merchandise.

### **Injury Reports**

1. Any injury involving any driver, owner, crew member, sponsor or any employee occurring on the racing premises, must be reported to the CARS Tour Technical Director or the medical personnel in charge, before leaving the premises (if said Member is able to make such a report). Otherwise, someone from the injured individual's crew should make CARS Tour Technical Director or the medical personnel in charge aware of said injury and to assist with the completion of an accident report by CARS Tour Tech Director.

## **SAFETY RESPONSIBILITIES**

### **General Safety**

1. All competitors are obligated to inspect the racing facilities,

safety personnel and equipment, and conditions of the track on a continuing basis before, during, and after the event. Since the competitors are closer to the racing facilities, safety personnel and equipment, and conditions at the track on a continuous basis throughout the event than CARS Tour Officials or the Promoter, it is their obligation to inspect, observe and report to the Promoter promptly any inadequacy in the facilities, personnel, equipment, or conditions at the track. Competitors also are solely and directly responsible for the safety of their race cars and racing equipment and are obligated to perform their duties (whether as a car owner, driver, or crew member) in a manner designed to minimize to the degree possible the risk of injury to themselves and others. Neither the CARS Tour nor the Promoter can or will be responsible for the adequacy of a competitor's race car, racing equipment, or racing activity to accomplish this purpose.

## **IDENTIFICATION AND SERIES SPONSORS**

CARS Tour reserves the right to approve or disapprove any advertising, sponsorship, message or similar agreement in connection with any event. CARS Tour competitors agree to accept any CARS Tour decision in the event such judgment occurs.

### **Car Numbers and Driver Names**

1. All cars are to have the number clearly readable on both doors at least 21" in height and 3" wide, on the roof at least 24" in height, and on upper right windshield decal at least 6" in height. Roof number should be readable from the left side of the car. All numbers must be decals only. No duct tape numbers will be allowed.
2. Primary car base color must be in high contrast to the number color to maximize visibility as well as to assist scorers.
3. No foil, aluminum or reflective type material permitted for use as car number.
4. Driver's names will be in letters easily read and on the roof over doors.
5. Numbers on replacement vehicles must be decals.
6. Letters being used as numbers must be visible in size and not be tape material.

### **Series Sponsor Decals**

1. CARS Tour reserves the right to require tour sponsor decals on cars. No competing series decals will be allowed on cars.
2. CARS Tour reserves the right to place a series sponsor decal on the front and side windshields.

3. CARS Tour reserves the right to place a series sponsor decal on the side window between B and C post.
4. Decals must be adhered to the race car as outlined by CARS Tour.
5. CARS Tour reserves the area from the "A" Post forward and the "B" Post for the placement of series sponsors and contingency award sponsors decals.
6. Additionally, CARS Tour reserves the rocker panel area as well as the lower rear bumper area for series' sponsor decals.

### **Driver/Team Apparel**

1. Drivers must wear approved fire suits with current SFI rating visible. Additionally, drivers must wear head and neck restraint devices, SFI approved gloves and shoes.
2. All crew members who participate in pit stops and/or go over the wall during the race event must wear SFI rated fire suits OR uniform team attire (matching pants and shirts). The wearing of helmets is optional.

## **RACE DAY PROCEDURES**

### **Drivers Meeting**

1. CARS Tour officials will conduct a drivers meeting at each race. At this meeting, all new or special information that may differ from rule book will be announced and will be considered official. The following guidelines will apply for all driver meetings.
2. A roll call along with a sign in sheet will start each meeting.
3. The driver, crew chief and spotter from each team are required to attend each driver's meeting.
4. Failure of driver, crew chief, or spotter to be present at roll call will result in a qualifying penalty.

### **Crew Chief Meeting**

1. CARS Tour will conduct a crew chief meeting immediately after the pit/garage area opens. Crew Chiefs will be advised of any abnormalities or peculiarities regarding the host track for the event and/or any differences in scheduling from normal activities.
2. All crew chiefs are required to attend. Failure for crew chief to attend will result in team losing practice time as determined by CARS Tour officials.

### **Qualifying Procedures**

Qualifying procedures will vary by race and will be published in advance on the event entry form and event schedule. Formats include but may not be limited to:

1. Single Car Qualifying

- A. Qualifying position to be determined through random selection at meeting.
  - B. All cars must clear tech before qualifying. Any car or driver not ready to qualify at the assigned time will be issued a qualifying penalty.
  - C. Upon clearing tech, cars are considered impounded and no more work is to be performed other than the adjustment of tire pressures. Any car that is worked on after tech will serve a qualifying penalty.
  - D. Competitors will single car qualify with a dead lap and either one (1) lap or two (2) lap time trials at the discretion of Series Director.
  - E. Pre-qualifying penalties will result in the slower of the two timed qualifying laps being the lap of record used for official scoring.**
2. Knock Out Qualifying
    - A. All qualifying laps must be started prior to the expiration of the qualifying clock.
    - B. The first round of knock out qualifying will consist of a ten-minute (10) clock (timed through scoring and race monitor) for competitors to complete a timed qualifying run.
    - C. The top eight (8) qualifiers from the first round will advance to the second and final round which will start following a three (3) minute break.
    - D. First round qualifiers that do not transfer to the second round will start in their timed qualifying order starting with the 9<sup>th</sup> position.
    - E. Second round knock out qualifying for the top eight (8) first round qualifiers will last for five (5) minutes (timed through scoring and race monitor).
    - F. Following second round knock out qualifying starting positions one (1) through eight (8) are determined by the fastest posted lap of each competitor from the second round.
    - G. Any competitor that impedes or interferes with another competitor's qualifying attempt, or otherwise engages in any unsafe act while on the racing surface (including pit road) during a qualifying attempt, may be subject to disciplinary action as determined by the Series Director. Disciplinary action may include, but is not limited to, disqualification of qualifying run.
    - H. Teams will be limited in adjustments that will be permitted during or in between runs as determined by the Series Director and will be communicated prior to each event.
    - I. All cars are subject to post qualifying tech following the completion of Knock Out Qualifying.
  3. All tires to be used in the race event will be marked. Teams are required to start the race on the same tires on which they qualified. After qualifying, teams may not change a tire unless it is flat or has serious damage. Tire changes will be at the discretion of CARS Tour officials.
  4. After qualifying, cars may not leave impounded area or have any work performed on them unless instructed by Technical Director or his designate. All cars will qualify race ready according to rules herein unless otherwise discussed in crew chief meeting qualifying. Only cars that have sustained damage during qualifying, have a serious safety issue, or have had a major mechanical (i.e.; blown engine) may be removed from the grid for repairs. In the event a team is granted permission to make a change, that car will be relegated to start at the rear of the field for the event. No work will be allowed on vehicles unless approved by Technical Director.
  5. No driver may attempt to qualify more than one (1) car in time trials. A qualified driver may change to a nonqualified car and start the race from the rear as long as it is same registered owner/owners number. A non-qualified driver may drive a qualified car if written permission is obtained from CARS Tour office prior to running of event. Permission will only be granted on a per event basis and only if circumstances warrant such permission. If approved, the car will start from the rear.
  6. When two or more competitors have duplicate fast lap times the tie will be broken by the next fastest lap time (if both lap times or single lap qualification times are the same, then the tie will go to the car with the highest standing in owner points). If owner point standings do not prevail, then the driver setting the duplicate time first would start in front of the other.
  7. Unless otherwise directed by CARS Tour, the fastest qualifier will be given the choice of starting on the pole or taking the outside position in the front row. The fastest qualifier will be used as the control car for the start.
  8. If qualifying is unable to be completed, the starting field will be determined by the combined times recorded in both practice sessions. If the second practice session was not held than the starting field will be determined by times from the first practice session. If practice and qualifying are both unable to be held, the starting field will be determined by CARS Tour owner point standings
  9. In postponed events where re-qualifying is specified, only the qualifying times established in re-qualifying will be certified as CARS Tour records.
  10. The exact starting field for each event will be determined via the entry form. The standard 28 car starting field will be determined as follows:
    - A. Qualifying positions 1-22 will be determined according to the fastest 22 cars in qualifying.
    - B. The next four (4) positions will be assigned to the top four (4) finishers in the "last chance" race, if one is necessary.
    - C. The final two starting positions (27<sup>th</sup>-28<sup>th</sup>) will be reserved for the licensed competitor who has filed a timely entry for the event and who has the most 2020 owners points who has not qualified for the event thru qualification or the "last chance race". For the first event of 2020, the final two starting positions will be determined by 2019 owner's points.

## Race Procedures

1. All drivers must be on time to compete in the events for which they are scheduled. Any driver late for the autograph session and/or driver introductions, as determined by CARS Tour Officials, shall be relegated to the rear of the field prior to the start of the race.
2. No changes of driver at any time will be made without advance notification to CARS Tour Officials. When the race is in progress, changes must be made in pits only.
3. Any qualified car may be driven in any event by a registered CARS Tour licensed driver. However, the driver who starts the car in the race will be awarded driver points for the event.
4. CARS Tour Officials will use flags, as set forth in this section, for the purpose of providing driver with information. Officials may use light signals in addition to or in lieu of flags. The procedure for use of flags and/or lights by Series officials may vary for individual series or races.
5. The initial start and all restarts will be double-file. On the initial start and all restarts, cars must maintain their positions as determined by CARS Tour officials until they have reached the designated starting box on the track as covered in the drivers meeting. In the event of a caution on the first lap of the race, the field will be restarted as per the original line up with the exception of the cars that were the reason for the caution----- they will restart at the rear of the field. On restarts, the race will resume immediately when the green flag is displayed. CARS Tour officials may make a special ruling on starts or restarts for any race (i.e., following a red flag, the yellow flag will constitute an official restart of the race).
6. All starts and restarts shall be made at a designated area on the track and made known to the drivers in the pre-race meeting.
7. The blue flag with a diagonal yellow stripe signifies that faster traffic is overtaking the cars being signaled. Cars being given this flag must yield to overtaking traffic as directed by CARS Tour Officials.
8. The yellow flag signifies caution and this flag will be given to the first car passing the starter immediately following the occurrence of the cause for caution. All cars receiving the yellow flag or light shall slow down to a cautious pace, hold their position, and form a single line behind the lead car. A pit entry flagman stationed at the entry to pit road will wave a red flag with a yellow cross that signifies that pit road is closed. Pit road entry procedures may vary from track to track and will be discussed at the drivers meeting prior to the event. When the yellow flag and/or caution lights are displayed, all competitors will cease racing and will not pass as long as all cars maintain a reasonable speed. Any car entering the pits prior to the pit road being deemed open by Race Control shall restart the race at the rear of the longest line of cars. Cars will restart in the order they were running at the completion of their last green flag lap.
9. Cars returning to the race track from the pits while the yellow flag is out must wait for the rear of the field in the line behind the pace car, or as otherwise directed by CARS Tour officials.
10. If the race goes forty (40) consecutive green flag laps without a natural occurring caution, a competition caution will occur. The only time this will not occur is if the fortieth (40<sup>th</sup>) consecutive green flag lap falls inside twenty-five (25) laps to go of the total race distance.
11. No car may pass the pace car unless directed to do so by Race Director. Any car passing the pace car unapproved will be assessed a one (1) lap penalty.
  - A. During a given caution period only one (1) car is eligible for the "Free Pass" per caution period. That car may be any number of laps down to the leader but the Free Pass will go to the first eligible car. The Free Pass can pit during this caution period. This car may only pass the pace car when directed to do so by the race director. If the first eligible car was part of the incident on the track which resulted in the current caution period, or the car eligible for the Lucky Dog pits, this car will forfeit their privilege and this privilege will not be passed on to any other car during the same caution period. Once the car passes the pace car, that car must restart at the tail end of the longest line.
  - B. Vehicles on the rear of the lead lap, in front of the race leader, and immediately behind the pace car may be directed to pass the pace car and proceed to the rear of the longest line. These vehicles may not advance until directed by the race director.
12. Pit attendants and crew members shall not go on the race track for any reason while the cars are racing, or while they are running under the yellow flag. The only time drivers or cars may receive service is when they are completely stopped in the pits.
13. The red/yellow combination of flag means racing must stop immediately regardless of the position of the cars on the track. Under red/yellow situation cars may enter pits, as safety allows, for crews to work on their cars, but only after the officials have given them permission to do so. All teams that work on their car under red/yellow situation under a red/yellow flag must restart at the tail of the field regardless of their previous position.
14. The red flag means that the race must be stopped immediately regardless of the position of the cars on the track. The red flag shall be used if, in the opinion of CARS Tour officials, the track is unsafe to continue to race or a prolonged caution period is anticipated. Cars should be brought to a stop in an area designated by CARS Tour officials.
  - A. No repairs or service of any nature will be permitted when the race is halted due to a red flag. All work must stop on any car in the pits when the red flag is displayed and work cannot be resumed until the race is placed under the yellow caution flag. Teams that work on a race car while under red flag will be assessed a two (2) lap penalty that can't be made up on a Free Pass.

15. The black flag means for the competitor to go to the pits immediately and report to the CARS official at the driver's pit. It does not mean automatic disqualification. If the driver does not obey the black flag directive for three (3) consecutive laps, the driver will then be given the black flag with a white cross to inform the driver that scoring of his or her car has been discontinued until further notice.
16. In lieu of a black flag, CARS Tour officials may use a blackboard or black flag number indicator in full view of the competitor on which the number of the car being black flagged will be shown.
17. When the white flag only is displayed, it means the leader has started his or her last lap. If the yellow flag is displayed during the white flag lap, all cars will cease racing and slow to a cautious speed. The race will not end under caution. The race will end with a green, white, checkered finish. The process will be repeated until the leader receives the checkered flag.
18. A car may not receive any assistance after the white flag has been displayed except a car being pushed on pit road. Violation will result in the car not being scored for that lap.
19. When the checkered flag is displayed, it means the race is completed. When the required race distance has been completed by the lead car, the race will be declared "official" regardless of any flag being displayed.
20. When the checkered flag is given to the leader, the balance of the field receives the checkered flag in the same lap. Finishing positions will be paid according to most laps traveled in the least time, whether the car is still running or not.
21. The winner of the event will bring his/her car to the start/finish line (or victory circle) while the second and third place finishers will drive directly to the tech facility for post race inspection. All others will enter their pit area immediately after receiving the checkered flag.
22. Special flags may be used at the discretion of CARS Tour officials, but must be explained to all drivers before the race starts.
23. Teams that work on a race car while on the racing surface while under yellow or red conditions will be disqualified.
24. Any person who ventures onto the racing surface during the event will be fined \$300.00 and/or face suspension.
25. No car will be permitted to continue in competition if, in the opinion of presiding CARS Tour officials, the car is a hazard to the other cars in the event.
26. Cars must take the checkered flag to win. Any race rained out or stopped because of curfew at one lap past halfway of the event will be considered a completed race.
27. Any driver who does not obey the flag rules may receive a fine and/or lap (s) or time penalty.
28. Any competitor who causes or attempts to cause a yellow flag by stopping his/her car or throwing debris on the racing surface may be assessed a fine and/or lap(s) penalty. Any car that stops on the racing surface during any pace laps must drop to the rear of the field.
  - A. Each team is responsible to insure the Technical

Director has the teams' current frequency.

- B. Each CARS Tour team will be responsible for providing a spotter, in a designated area for spotters, for their vehicle at any time the vehicle is on the track either in practice, qualifying, or racing. This spotter **MUST** be capable of monitoring race control frequency at all times (even when the team's primary frequency is in use) and be capable of communicating messages to his/her driver as directed by CARS Race Control. All Spotters must attend the 'driver, crew chief, spotters' meetings. Failure to attend the meeting(s) will result in a car becoming a "one (1) lap qualifier"

### **"IN-RACE" Pit Stop Procedures**

1. When following the pace car under a caution flag, driver must maintain their position in relation to other cars in the field or as otherwise directed by tour officials. Pit road opening/closing shall be controlled by the use of lights or flags. Cars choosing to pit must drop down to enter the pits at entrance/apron of pit road. Pit procedures for each event will be determined in CARS Tour driver/crew chief meeting prior to the event.
2. All equipment used to service the car must be removed from the car prior to the car leaving its assigned area. All equipment and crew members must be on "Safe Side" of pit stall prior to car leaving its assigned pit area.
3. When pit stops are made for a tire change, all lug nuts must be fully tightened before the car leaves the assigned pit area. If the pit road official detects a violation, the car must return to its assigned pit area for inspection.
4. Unless otherwise authorized when making a pit stop, only five (5) pit crew members will be allowed over the pit wall.
5. Any competitor who goes behind the wall or to the infield for repairs during an event will be considered retired from the race.
6. Only one (1) jack and two (2) wrenches (air or manual) can be used for any pit stop involving tire changes. The same jack must be used when tires are changed on the left and right side during the same pit stop. In the event a car falls off a jack, a second jack can be used on the same side to facilitate use of the first jack.
7. Cars must be completely in their respective pit box during pit stops (as space permits).
8. Race cars exiting pit road under caution flag will not be allowed to blend into traffic but must fall into line behind the last car on the track. **DO NOT ADVANCE.** Cars which advance will be moved to the rear.
9. Cars entering on pit road must not exceed pace car speed. The pace car will maintain "Pit Road Speed" during warm up laps. Drivers will note their gear and tachometer at this time and will not exceed this speed at any time while on pit road. Speeding on pit road will be enforced at all times. Cars speeding on pit road will be moved to rear of the field.
10. The tour reserves the right to change, alter, or add to pit stop rules at any event. In the event rule changes are

implemented at the race track, such changes will be discussed at the driver's meeting.

11. Pit assignments will be assigned by CARS Tour officials as early as possible and will be determined through CARS Tour officials.
12. MANDATORY: Teams must have a minimum 10# fully charged fire extinguisher in their pit area. Any team found in violation will be fined \$100 and will start in the rear.
13. No smoking within 15 feet of pit stalls. Failure to comply will incur a fine of \$100 per incident.

## **Timing and Scoring**

1. The tour official designated by CARS to be the Director of Scoring for an event is totally responsible for scoring the event. The decisions of the Scoring Director, with respect to timing and scoring, are final unless the Scoring Director elects to request a re-check by the CARS Tour office or when the Scoring Director is asked by a competitor who has competed in the event to submit a request for such recheck to tour office.
2. When possible the UNOFFICIAL finish will be posted at the command center within one (1) hour of the checkered flag.
3. A scoring protest must be written and accompanied by a \$250 NON-REFUNDABLE service fee and be presented to the Series Director or Scoring Director within one (1) hour of the posted finish. No protests will be accepted after that time.
4. If possible scoring rechecks will be done at the track. If it is an extensive recheck, the office will have five (5) working days to recheck the scoring and post an official finish. Until that time, the finish is not considered official. Decisions of the CARS Tour office on a scoring re-check are final, non-appealable and non-litigable.

## **Rain Delay and Cancellation**

1. In the event that weather, or any other unforeseen situation, would prohibit the CARS Tour event to be held on the advertised date. The event will be scheduled for next day, if possible. If the next day is not an option, event will be re-scheduled on a later date or cancelled altogether. This decision will be at the sole discretion of the Series Director.
2. There shall be no refunds for grandstand tickets, entry fees or pit passes. All grandstand tickets, entry fees and pit passes will be honored at the next scheduled CARS Tour.
3. Tour officials reserve the right to change these procedures as applied to that particular situation, as well as reserve the right to cancel the event altogether.

## **CONDUCT & PENALTIES**

### **Conduct Violations**

1. If a CARS Tour official in his/her sole and absolute discretion determines an act of commission or omission by a CARS Tour member that constitutes a violation of the

CARS Tour Series Rules or that is detrimental to auto racing or to the CARS Tour, and if the tour official in his/her sole and absolute discretion determines that the act of commission or omission is sufficiently serious to warrant the imposition of a penalty, the Official shall report the violation in written detail to the tour director as soon as practicable, and shall recommend an appropriate penalty. The tour director shall consider the report, and shall conduct whatever additional inquiry deemed appropriate under the circumstances. After concluding the inquiry, the tour director shall determine whether disciplinary action is appropriate, and if so, what disciplinary action should be taken. The Member shall be informed of the determination, and if disciplinary action is imposed, the tour director shall issue a penalty notice to the Member specifying the violation, a brief statement of the circumstances of the violation, and the penalty imposed.

2. If the act of commission/omission of a Member is determined by a CARS Tour official to constitute a threat to the orderly conduct of the race, that Official may take temporary emergency action against the Member. Such emergency action may include ejection from the racing premises, temporary or permanent suspension or any other action designed to remove the threat created by the Member. Examples of conduct warranting such emergency action include, but are not limited to, the consumption of alcoholic beverages or drugs before, during or after an event, the use of illegal drugs at any time, fighting, reckless driving, and failure to obey the black flag or any other directive of an official. The CARS official shall report the Member's conduct to the tour director as soon as practical, and thereafter the procedure set forth above shall apply. The emergency action shall remain in effect until the decision of the Series Director is made which shall be final.
3. Fines shall be paid to CARS Tour office in Mooresville, NC, promptly after receipt of a penalty notice. Failure to pay promptly will result in suspension. All unpaid fines of a Member may be collected by the Series by deducting the amount from the purse earnings of the Member, or if the Member is not an owner, from the purse earnings of the owner with whom the Member was associated at the time of the conduct that gave rise to the penalty notice. All fines will be paid before entry for the next event.

### **Penalties**

1. Penalties for violation of CARS Tour Rules are determined by the gravity of the violation and its effects on fairness of competition, the orderly conduct of the event, and the interests of stock car racing and the Series. Such penalties may include, but are not limited to, disqualification, suspension, fines and/or loss of points. A suspension may be permanent or for a specified or indefinite period of time. The tour director may use the following as guidelines for the imposition of penalties in the situations described below, but these guidelines shall not limit the authority of

the Director.

- A. Any Member who performs an act or participated in actions deemed by CARS Tour officials as detrimental to automobile racing or to the CARS Tour, a fine of at least \$500.00, suspension of those persons involved in the act, and/or loss of championship points
- B. Any owner whose car is found with a traction control device (working or not) will be suspended indefinitely.
- C. Any Member who signs the tour release sheet or competitor pit permit for anyone else; a fine of at least \$500.00 and suspension.
- D. Any member who assaults or threatens to do bodily harm to any CARS official or persons serving under their direction; a minimum fine of \$ 1000.00, suspension, and/or loss of championship points.
- E. Any Member who, while participating in a Series sanctioned event, partakes of any alcoholic beverage, stimulating, depressing or tranquilizing drugs, or is otherwise under the influence of alcohol or drugs, will be suspended indefinitely.
- F. Any Member who participates in fights in pits, track or on any of the track property, a minimum fine of \$500.00 with possible suspension.
- G. Any Member who commits an assault with a weapon of any description in the pits, on the track or on any of the track premises; a minimum fine of \$5000.00, a suspension and/or loss of championship points.
- H. Any Member who permits a car to be driven in any CARS Tour sanctioned event by an unlicensed person, or who fail to notify CARS officials of any change of driver during a race may be fined up to \$1,000.00 and/or suspended.
- I. In an event where the CARS officials mandate post race inspection of a car that has competed in the event and that car is taken from the racing premises without permission of a CARS official, the car will be disqualified unless the competitor proves beyond any reasonable doubt that the violation was caused by circumstances which the competitor could not control.
- J. Any member who fails to tear down a car for inspection when requested to do so by the CARS official; a fine of not less than \$1,000.00, and/or disqualification, and/or loss of championship points, and/or definite or indefinite suspension from the Series.
- K. Any determination by CARS officials that parts and/or equipment used in the event do not conform to CARS Tour rules or have not been approved by the CARS Tour prior to the event or which are not required for the normal functional operations of the race car or safety items which have been altered to detract from or compromise their integrity or effectiveness, disallowance of qualifying times, withdrawal of opportunity to qualify for the event, and/or fine, and/or suspension from CARS Tour.
- L. Any member failing to surrender to CARS Tour any

part and/or equipment found during an inspection, a fine and/or loss of finishing positions in the event, and/or loss of championship points, and/or definite or indefinite suspension from the Series.

- M. Any concealed pressure type containers; feed lines or actuating mechanism when found in the car or on the person of a competitor even if inoperable, a fine of not less than \$1000.00, and/or loss of championship points, and/or definite or indefinite suspension from the CARS Tour.
- N. Any modification that permits the lowering of a race car while in competition, including but not limited to the wedging of springs and shock absorbers or any modification that permits the lowering of a race car while in competition, or any car that is found to be under the specified height requirement after the completion of time trials or the race, disallowance of qualifying time, and/or loss of championship points, a fine, and/or lap (s) or time penalty.
- O. Any violation of fuel cell or fuel cell container specifications; a fine, and/or loss of championship points, and/or definite or indefinite suspension from CARS Tour.
- P. Any competitor found using, in his or her car, automated electronic recording devices, on board computers, and the likes, which have not been approved by CARS Tour prior to the event; a fine or \$1000.00, and/or loss of championship points, and/or definite or indefinite suspension from the CARS Tour Series.
- Q. Use of altered fuel or fuel other than the official fuel at the event, a fine, and/or loss of finishing position, championship points, and/or definite or indefinite suspension from CARS. Failure to cooperate with tour officials in obtaining fuel samples at any time during an event will subject the car to disqualification, and will subject the crew chief and/or car owner to additional penalties deemed appropriate by Series officials.
- R. Use of any tire or tires that have been altered by unauthorized treatment to the tread area disallowance of qualifying times, withdrawal of the opportunity to qualify for the event, and/or minimum fine of \$500.00 per tire, and/or loss of finishing position in the event, and/or suspension from the tour.
- S. Any car starting the race on tires other than its qualifying tires, a fine and/or loss of championship points, and/or definite or indefinite suspension from CARS Tour.
- T. Any team found using any tire(s) that has not been impounded for that event will be assessed a one (1) lap penalty at the conclusion of the event.

## **Race & Pit Procedure Penalties**

- 1. "To Rear of Longest Line"
  - A. speeding on pit road
  - B. too many over pit wall

- C. dropping down too soon or late for pits
  - D. pit outside of designated area
  - E. entering a closed pit
  - F. "reckless" driving
  - G. working on car red/yellow flag
  - H. use of illegal or unauthorized equipment during pit stop
2. "Stop & Go"-----under green flag.
    - A. too fast down pit road under green
    - B. failure to line up in correct position with position gain or restart in wrong line with position gain
    - C. running stop sign
    - D. not holding lane until from start to finish line
  3. "Lap/Laps Penalty"
    - A. unauthorized pass of pace car
    - B. failure to obey flags
    - C. intentional yellow
    - D. work on car during red flag
    - E. "rough" driving/retaliation
  4. "Black Flag/D.Q'/Other"
    - A. car work on race surface
    - B. ignore black flag for 3 laps
    - C. car aided on white flag lap
    - D. FLAGRANT "rough" driving.

## **CARS TOUR INSPECTIONS**

### **Inspections**

1. All vehicles will pass through technical inspection before qualifying for all CARS events. All inspections will be performed as designated by Technical Director and may vary from race to race.
  - A. All general safety as well as technical and general appearance guidelines must be adhered to before vehicle will be allowed to compete.

### **Post Race Inspections & Penalties**

1. There will be no tolerance to rules unless specified. Failure to comply with rules MAY result in disqualification from qualifying position, finishing position or disqualification from event entirely
2. Series' weighing, measuring and testing devices as well as procedures used by CARS Tour technical officials are the standards which determine a vehicles compliance with tour rules and regulations. No other equipment or device may be used unless approved by CARS Tour Technical Director.
3. The decision on rules infractions during pre-qualifying or post-race technical inspections as imposed by the Technical Director shall be final and non-appealable.

### **Non-Conforming Parts**

1. CARS reserve the right to confiscate any non-conforming and/or unapproved part (s).
2. Any use of components utilizing mercury for the enhancement of performance shall be deemed to render the vehicle ineligible to compete in the Series and such violation

of law shall be reported to the appropriate authorities. Any clean-up and fines will be the car owner's responsibility.

## **APPEALS**

The CARS Tour Director or his designate shall have final authority for any and all decisions regarding the CARS Series.

### **Appeals Procedure**

1. A car owner may file an appeal against a penalty imposed by the CARS Tour Director provided that the individual submits an "Intent to Appeal" letter to the Series Director within five (5) days of the penalty notice.
2. Appeals must be in writing and accompanied by the non-refundable appeal fee of \$500.00.
3. The CARS Tour Director shall be responsible for the orderly disposal of such appeals by appointing an Appeals Board. The Board shall be comprised of members or officials at discretion of CARS Tour Director. The time and date of the appeals hearing will be as soon as possible at the Series Director's sole and absolute discretion.
4. Three members shall constitute a quorum for the Appeals Board.
5. The Board shall establish procedures for hearing the appeal and shall not be bound by technical or formal rules of evidence or procedure. The hearing will be conducted in the manner best suited to the relevant facts.
6. Cost of the proceedings shall be at the expense of the CARS Tour. However, if the Board determines that the appeal may have been instituted without merit, the cost for such hearing will be the responsibility of the Member who instituted the charge.
7. The appellant may not file an appeal against the judgment issued by the Board of Appeals.
8. The CARS Tour Board of Appeals, the Director, nor any other body shall order an event to be rerun.
9. The Series shall have the right to publish the judgment of the tour Board of Appeals and to use the names involved. The persons or teams so named shall have no recourse to act against these parties or the publisher of the judgment.
10. Race procedure calls are considered judgment calls and shall be non-appealable and non-litigable.

## Owner/Driver Championship Points System

1st	33	19 <sup>th</sup>	14
2nd	31	20 <sup>th</sup>	13
3rd	30	21 <sup>st</sup>	12
4th	29	22 <sup>nd</sup>	11
5th	28	23 <sup>rd</sup>	10
6th	27	24 <sup>th</sup>	9
7th	26	25 <sup>th</sup>	8
8th	25	26 <sup>th</sup>	7
9th	24	27 <sup>th</sup>	6
10 <sup>th</sup>	23	28 <sup>th</sup>	5
11 <sup>th</sup>	22	DNQ	2
12 <sup>th</sup>	21		
13 <sup>th</sup>	20		
14 <sup>th</sup>	19		
15 <sup>th</sup>	18		
16 <sup>th</sup>	17		
17 <sup>th</sup>	16		
18 <sup>th</sup>	15		

\*All cars that do not qualify for feature event will receive two (2) championship point if completed a qualifying attempt.

### Bonus Points Program

1. Lap leader - one (1) point awarded to each driver who leads at least one lap.
2. Pole - one (1) point awarded to winner of pole at each event **if** qualifying is completed.
3. Leader of most laps - one (1) event point.

### Year-End Series Point System

1. Car with the most 2020 wins will receive a two (2) point bonus at years' end.
2. Car with most 2020 poles will receive a one (1) point bonus in the final point standings.
3. Drivers and Owners championship shall be determined by driver/owner earning most points in events during the 2020 season plus any bonus points earned. In case of tie, Champion will be determined by most wins, most seconds, etc., until tie is broken.
4. All other point positions ending in a tie will be handled in the same manner.

# 2020 Super Late Model Specifications & Guidelines



**IMPORTANT:** Competitors **MUST READ** the “Additional Series/Track Rules” Section at the end for additional rules specific to a Track or Series.

## A. Eligible Cars and Bodies Guidelines

1. All competing cars will be full-sized, stock American manufactured passenger car bodies. 2018 A-B-C Body Rules apply unless otherwise specified herein. Refer to A-B-C Rulebook and guidelines for details. Also, no panels allowed extending top edge of doors. No under car panning outside of frame rails and no further than drivers' tub front or rear at the bottom of the frame. Maximum drivers tub length is 52 ½ and the maximum width of frame is 53 ½. Any holes in body not being used must be covered and remain so during the race. **The Five Star 2019 Gen 6 Super Late Model body is not allowed.**
2. A-Pillar vent windows may only have 1/2 inch of straight line deflection. The surface must be smooth and must not have bead rolls or breaks. Front nose valance may only be a single layer and be a maximum of 3/16" thick and may be a maximum of 3" tall **and may not cover the grill screen.**
3. Rub rail are discouraged and may only be used if they are polycarbonate.
4. If exhaust exits through the door, installation must include an exhaust flange that is mounted flush to the door. Maximum ½" gap around the exhaust pipe. Pipe must not protrude through door.
5. At all times, the ABC "A" measurement must maintain a min. length of 11.5 inches. Also, 20 inches is the min. length allowed for the nose, measured from the bottom, leading edge at center, up to the hood seam. **Measurements strictly enforced.**
6. The air box between the nose and radiator may have no pieces wider than the radiator. Nothing may be used to restrict the flow of air in the ductwork between the nose and radiator. The standard opening for the grill screen area, as approved for manufacturers production, must be maintained at all times. Only ABC manufactures standard mesh screen may be used for the radiator opening in the nose. **No cool down units, pumps, or exotic fans allowed.**
7. No types of under-body air deflectors are allowed. All air for blowers or coolers in the engine compartment must be pulled from the nose or the radiator air box. Air may not be blown or forced onto the tire or bead, air may only be directed to the brake rotors. The duct work between the nose and the radiator may be no wider than 29" and may not be carbon fiber. **NACA ducts in the ¼ window must only supply air to helmet cooler or other specific item. They may not lead to open blowing in the cockpit.**
8. Tape may not be used anywhere on the car to control the flow of air or seal/secure seams between the body panels (unless approved for repairs). The only exception is that tape may be used on the radiator grill opening and brake ducts in the nose.
9. **No window tint of any kind will be allowed on windows or spoiler.**
10. **Titanium, Inconel, or exotic metals are not allowed for use in any way on the race car. No hollowed-out bolts of any kind on suspension components.**
11. 66 inch maximum tread width for all cars.
12. Interiors must be steel or aluminum only.
13. No Data Acquisition equipment/wiring is allowed in the car on officially recognized race or practice days. Sanctioned optional test days are allowed. **No digital dashes allowed. Cellphone, smart watches, or Bluetooth devices will be allowed in car during qualifying or race. This is an automatic disqualification.**
14. Scoring transponders must be placed on the inside of the left rear frame rail, 11 inches from the back of the edge of the axle tube to the centerline of the transponder bracket.
15. Minimum Base Weight: 2800 lbs (see "Series/Track Additional Rules" section for additional weight breaks or penalties). 58.0% Max. left side weight at all times (without refueling). For post-race total weight rules, teams may refuel, or officials may utilize "1 lb. per lap" burn-off.
16. **Minimum and maximum nose heights will be: Minimum nose, body, and frame height is 4" and maximum is 8".**

## B. Engines

### ***Basic Engine Guidelines***

1. Use of any engine under 347 Cubic Inches will require a 50lb penalty.
2. Engines with rear mounted distributors will be located so the forward most spark plug is no more than two inches (2") from the center line of the upper ball joints. Engines with front mounted distributors: up to four inches (4") setback from centerline of upper ball joints. Crate Engines may use four inch (4") setback.
3. Engines may not be offset more than one inch (1") from centerline of car.
4. Front center of crankshaft must have at least ten inches (10") of ground clearance. Crate Engines must be at least 11 inches.

5. Standard steel blocks only. No Carbon Compacted blocks of any type.
6. No Ford D3, SC, or other High Port heads. The following are the ONLY approved Ford heads: A, B, C, C3, and C35. These heads must remain unaltered other than porting and polishing. No altering of these heads will be allowed so as to change runner floor or roof height to raise port or ports, these heads will be considered high ports and are not permitted. Runner floor and runner roof heights must remain as manufactured from Ford.
7. No Overhead Camshafts.
8. A maximum 16 inch (O.D.) air element and housing must be used.
9. Carburetor restriction must be done with a solid plate or cone type system only, and may NOT be externally adjustable in any way. No adjustments may be made to the carb/restrictor package following qualifying. Teams will race with the same package they qualify with.
10. Any competitor that finishes in the top 5 may be required, at their expense, to remove the intake, heads, and/or oil pan for inspection purposes.
11. Externally lightened blocks will receive a 25-50lb total weight penalty.
12. **All oil pumps must be mounted in front of engine.**

**9:1 Compression Engine 362 Max Cubic Inches/Cast Iron Block**  
**(This package will be eliminated in 2021)**

1. Cannot exceed 9.5:1 compression. Method of determining compression will be at the discretion of Officials.
2. Minimum valve angle: GM-18 degrees; Ford 9 degrees with 4 degrees valve center; and Mopar 12 degrees. (+/- 2 degrees)
3. Steel or aluminum cylinder heads.
4. Steel standard production crankshaft; balancing, lightening, stroking allowed.
5. Any camshaft, any steel lifter, any rockers arms. Gear drives allowed.
6. Steel or aluminum intake. No fabricated intakes. No material may be added to production intake manifold to increase carb height. No welded-on spacers or air deflection devices allowed in intake. No part of carb spacer shall enter the intake.
7. 390 CFM 4bbl Part #6895 or #80507. Carburetors must pass inspection at any time regardless of temperature. Booster bar may be removed from center of booster (max inside dia. of booster .473) and the booster may be tapered from the center seam down (booster must retain .700 length minimum) but all 4 boosters must be the same style. No other modifications are allowed on carbs.
8. 1" Maximum spacer allowed but cannot extend into manifold.
9. 8200 rpm max.

**Southern Super Parts Engine (SSPE)**

(May Be Claimed for \$21,000 + pulling fee)

1. Maximum Engine displacement is 362 cubic inches.
2. Maximum compression ratio is 11.5:1 with +.5 tolerance.

3. Any flat top piston permitted with 927 wrist pin and **1mm x 1mm x 2mm** ring package only. Pistons must not extend out of the top of engine block. Maximum racer cost of **\$1500.00** per set.
4. Cast Iron engine blocks only. **No lightened blocks.**
5. Intake must remain stock. Absolutely no match porting or blasting of any kind permitted. Slotting of bolt holes, water lines and matching of sides allowed. Ford part #: Edelbrock 2928, 2929, or 2934 only. Chevy part#: Edelbrock 2814 or 2892 only.
6. Crankshaft must have a minimum weight of 40 pounds (with front timing pulley or sprocket). Minimum main size Chevy 2.300/ Ford 2.250. Maximum advertised racer cost of **\$2,200.00**
7. Connecting rods: Minimum rod journal size 1.850". Absolutely no piston-guided rods permitted. Maximum racer cost of **\$1,600.00** per set. No titanium rods permitted. Minimum rod weight **540** grams.
8. Listed Brodix Cylinder Heads only. Heads may be surfaced to achieve proper compression ratio. Absolutely no other work of any kind will be permitted to the intake ports, exhaust ports, or combustion chambers. Ford part #: SP STS T-1 F Std 225-SSPE. Must retain minimum valve angle of 20°. Chevy Part #: SP STS T-1 Std 227-SSPE. Must retain min. valve angle of 21°. Multi-angle valve job permitted. Absolutely no blending of valve job below valve seat permitted. Chamber must retain shape 3/8" above valve seat. Minimal blending due to multi-valve jobs permitted.
9. Maximum valve size: Intake 2.08", Exhaust 1.60", Stem size 11/32". Intake valve may be titanium or stainless steel. Exhaust must be stainless steel.
10. No Titanium valve springs permitted. Maximum racer cost: **\$500.00** per set. Titanium retainers permitted. Lock angles not specified.
11. Camshaft must be Comp Cam Part #: 21151712. Camshaft must be installed on 104° intake centerline +/- 1°. Roller lifters, maximum racer cost of **\$750.00** per set. Maximum lift of .715" while using 1.6 rockers checked at valve with zero lash. Maximum 1.6 rocker arm racer cost of **\$1,600.00** per set. Magnetic-type push rods only. No keyway guided lifters permitted.
12. Maximum 5 stage dry sump oil pump permitted. Max. racer cost of **\$1,500.00.**
13. Oil pan must have 1" inspection hole. Absolutely no sectional pans permitted. Open box pans only (NO windage tray / scrapers etc.). Max. racer cost of **\$700.00.**
14. Ignition System may only be FAST Ignition part # 6000-6701. Mount on right side of car dials point out the passenger side. The mag positive & negative shall be a maximum length of 62 inches. Must be remain uncut or spliced and on top of dash in clear view. Mandatory **7800** RPM Rev Limiter must be installed and fully functional. Absolutely no crank trigger pickups permitted.
15. Carburetor must be an unaltered 750 CFM 4779, 80528 Holley permitted. Carburetor must pass inspection at any time regardless of temperature. Maximum 1" carburetor spacer permitted on Ford motor only. Maximum 1/2" carburetor spacer permitted on Chevrolet motor only. Teams are required to bring a 1.350" carb restrictor that series officials may require to be

used with this engine package. Details may be found on each event's entry form.

16. No internally lightened blocks.

#### **"Other Engines"**

1. S.E.A.L. approved McGunegill, Hamner, and Florida SPEC "Sealed Engines" may also be used. The 6 existing Ford 374D engines are grandfathered for another year. That package will be eliminated in the near future. No new Ford 374D engines may be built. If necessary, series officials may add or subtract weight to ensure fair competition. Any tampering of seals or established construction of these engines is grounds for immediate disqualification. Additional tech rules will apply. The maximum RPM is the series mandated 7600 for the McGunegill, Hamner, Florida SPEC, and Ford S374D. Rev limiting device must be operational at all times with RPM Dials securely covered. All Sealed engines must use the gauge legal, 750 carb as described in the SSPE section. No internally lightened blocks.
2. The "ACE" Engine as commonly used in the ARCA Midwest Tour may also be used with a 750 carb as described in SSPE engine section. Series officials may add or subtract weight to ensure fair competition. 7800 RPM max
3. Crate engines may also be used. Series officials may add or subtract weight to ensure fair competition. Cars utilizing crate engines must use the engine, carb and ignition specifications that will be announced by tour officials prior to the event.

#### **C. Fuel System**

1. **VP-110** is the spec fuel of the CARS Super Late Model Tour. 20-gallon minimum purchase required at each event. Fuel samples may be taken at any time and tested. Alcohol, nitro-methane, nitrous oxide, other oxygenating agents, other additives and/or fuels that contain masking agents or oxygen are not permitted. Street-use pump gas is not allowed. Use of such substances or additives will result in immediate disqualification and loss of points.
2. No electric fuel pumps or forced induction of any kind are permitted.
3. No icing or cooling of fuel system.
4. A fuel cell will be mandatory with a 22-gallon (U.S.) maximum. Fuel cell must have a minimum of eight inches (8") ground clearance. Fuel cell must be equipped with at least two (2) protective straps completely around the cell. Fuel cell must be mounted securely behind the rear axle of the car. Cars must have a minimum 1/8" steel plate, or similar strength aluminum plate, between fuel cell and rear end. A similar plate at the rear of the fuel cell is recommended. All cars must have safety bar at the rear of the fuel cell. At a minimum, all fuel cell configurations must include a rubber type cell in a steel container. No "U" Shaped Fuel Cells or non-standard-shaped fuel cells.

#### **D. Ignition**

1. Battery powered ignition. Vehicle MUST start under own power.
2. Maximum 16 Volt Battery. Car must be capable of being started with a 12-volt battery. No Magnetos.

3. **The Nelson Specialists/SRL harness/Quick Car part number: #50-2053 spec wiring harness is highly recommended for 2020 and will be mandatory for 2021.** All wiring must be sealed. No unplugged wiring. All ignition boxes must be mounted on the passenger side, in plain view, and out of reach of the driver...and...all wires to the distributor must be run separately and not part of a bigger loom or wiring harness.

4. All teams must only use the following ignition system: ONE Crane Cams Ignition part# 6000-6700 (HI-6RC) and a Coil part# 730-0192 (PS92N), mounted on a tray as specified by CARS Tour officials. **This setup may be swapped out by officials at any time.**

#### **E. Suspension**

1. No fifth (5th) coil, or lift bar suspensions will be permitted. No birdcage set-ups of any kind (3 or 4 link). Trailing arms must mount to rear end in a solid fashion (heim allowed) and no part of the trailing arm mounting may freely rotate around the rear end. All parts of the rear suspension must be solid, one piece construction with no moving parts, with one heim at each end. All mounts for trailing arms, third links and track bars must also be solid and may not have the ability to move.
2. The wheelbase difference from left to right may not exceed 1/2 inch.
3. No driver adjustments other than ONE adjuster for brakes.
4. Coil Springs and Spindles must be Steel. (Exception: approved Coleman Spindle)
5. No traction control devices, electronic or otherwise, will be permitted. Use of traction control will be cause for immediate D.Q. and suspension from series.
6. One shock per wheel. Shocks must be only mechanical in nature and no part of suspension or shocks may utilize electricity.
7. Maximum one (1) coil spring and one (1) bump spring associated with each wheel.

#### **F. Wheels and Tires**

1. CARS Tour Hoosier F-45RS is spec tire on both the left and right sides unless otherwise noted on event entry form.
2. **Steel 10" wheels, lug nuts, and studs only.**
3. Bleeders are not allowed. Hidden bleeders will be checked for.
4. Cars must start the feature on the same tires on which they qualified. Cars running the last chance race may change tires prior to that race, but must return to the qualifying tire for the feature. Cars that run the last chance race on qualifying tires will be allowed to change tires prior to the feature.
5. Use of tire softening or altering agents will not be permitted. Use of such substances will result in immediate disqualification, loss of points and money.

#### **G. Transmission, Driveshaft, Rear End**

1. Full standard type transmission only will be permitted. No quick-change transmissions will be permitted. Automatic transmissions will not be permitted. Crate engine teams may use their transmission rules with no weight penalty.
2. A minimum of one reverse and two forward gears will be required.

3. Multi-disc clutches will be permitted. No direct drives. Conventional clutch mounted to fly wheel only will be permitted. Any transmission that does not meet these guidelines may be assessed a minimum 25 lbs penalty.
4. No carbon fiber or nonstandard material clutches. **The minimum clutch diameter is 5.5"**. No "slipper" or "centrifugal" clutches allowed.
5. Driveshaft must be equipped with a minimum of two (2) safety straps and must be painted white. Drive shafts must be made of Aluminum or Steel only, and use no other materials (i.e. carbon fiber, etc).
6. **Cars must utilize a working locked rear end (ex: spool or similar). This is mandatory for 2020. No part of the spool may move or twist.**

#### H. Brakes

1. Vehicle must be equipped with four-wheel hydraulic brakes.
2. No carbon fiber rotors. **Only steel rotors are allowed (no titanium).**
3. Brake fluid circulators permitted. Liquid or gas cooling not permitted.

#### I. Safety

1. Radio communication to the drivers is mandatory, with a minimum of one (1) spotter for each team. Spotter must have the capability to monitor series race control with a scanner.
2. Approved seat belts and double shoulder harness will be required, no older than five (5) years. A crotch strap will be required.
3. A capable form of head & neck restraint must be used. A strap-type neck restraint is mandatory (No Neck Collars). Drivers will not be allowed on the racetrack at any time without proper neck restraints in place.
4. Helmet must be 2005 Snell standard or better and have sticker visible for inspection. Full-face helmets required.
5. Clean, full driving suit, approved gloves, and shoes for fire protection are mandatory.
6. Side plate for driver's door will be mandatory. Must be 12 inches (12") high post-to-post, 1/16" minimum thickness steel or and must be fastened with a minimum of six (6) half-inch bolts or securely welded to series' approval.
7. Driver's window must be equipped with safety net with quick release-latch. String window nets will not be permitted. The minimum net size must be 22" wide and 16" high. When latched, the window net must fit and pull tight.
8. Resilient padding designed for roll bar use must be installed on any roll cage member which can be reached by any extremity of the driver while driver is normally seated with restraints fastened. Steering wheel must be padded.
9. All lead weights must be painted white, with the car number painted on each individual piece. All lead weights must be securely fastened. No lead weights will be permitted in driver's compartment. Any lost weight will result in a \$10 per pound fine. *No Tungsten or similar weight allowed!*
10. All competing teams must possess a minimum 10 lb. Aluminum working fire extinguisher while in attendance in pits, and this

item must be presented at inspection. Car number must be painted on fire extinguisher

11. A main electrical cut-off switch needs to be clearly marked and easily accessible to safety crews.
12. Numbers must be a minimum of 21" in height, with body of each character a minimum of 3" in width and must be professionally placed on each door. A number will be required on top, readable from the infield.
13. A car number at least six inches (6") in height must be placed in the upper right hand corner of the windshield.
14. Roll cage must be constructed of 1 3/4" OD round steel tubing with a minimum wall thickness of .090". Three inches (3") maximum gussets measured diagonally must be welded in main roll cage area where a 90 degree angle exists or where the roll cage meets the main frame rails. The main frame rails / bolt-on clips must be steel from radiator area to behind the fuel cell. Main Frame rails must be a minimum of 2" x 3" rectangular steel. Bumper bars and right side door bars must be a minimum of .065 x 1 1/4 inch tubing.
15. No part of any cooling system may be located in driver's compartment
16. Batteries must be securely fastened and mounted outside of driver's compartment.
17. A working Fire Suppression system or driver accessible fire extinguisher is required. All cars must have an STAUBLI Quick Disconnect or SRI Performance vacuum style fuel shut off placed at the point the fuel exits the cell.

#### J. Economy Package

1. **Packages for shocks and/or transmissions may be announced at a later date.**

#### OFFICIAL DECISIONS

1. Any situation not specifically covered in these rules will be acted upon by the official or officials in charge at the time, whose decision will be final and binding on all participants.
2. Any disagreement over technical questions or operations will be resolved by series officials. When decision is rendered, decision is final and binding
3. Continuous developments in racing may necessitate changes which cannot be anticipated at the time rules are formulated. If necessary, rules may be updated, changed, deleted or added to at the discretion of the officials.
4. At certain events, to encourage participation of local competitors, the officials may alter the rules for those cars to try

#### **Additional CARS Tour Rules Section**

1. Sealed Engine Alliance Leaders (S.E.A.L.) approved crate engines GM#88958604/Ford M06007-D347-SR/McGuneGill Ford 425 LM engines will have a base weight of **2750 lbs.** with 58% left side weight at all times. Chevy 604 engines with GM FastBurn upgrade cam #24502586 are allowed. Engines without S.E.A.L. seals will carry **50 lbs.** weight penalty. Holley 650 HP 4150-80541 is the only approved carburetor. Maximum RPM for Ford is 6500 and maximum RPM for Chevy is 6600. Additional weight breaks, if any, will be announced on the event entry form.
2. Where a 750 carb is allowed for use, a team may also use a CARS Tour gauge-legal 650, 390, or 500 2bbl. 9:1 may use the 500 bbl.
3. All competitors must read and abide by CARS Tour general rules and race procedures.
4. Teams are allowed two (2) Hoosier F-45SX stagger tires per race set. Additional stagger tires will be available for practice.

and create a level playing field for cars that might fall outside of the normal rules. Official's decisions are final.

## 2020 ABC Approved Body Measurements

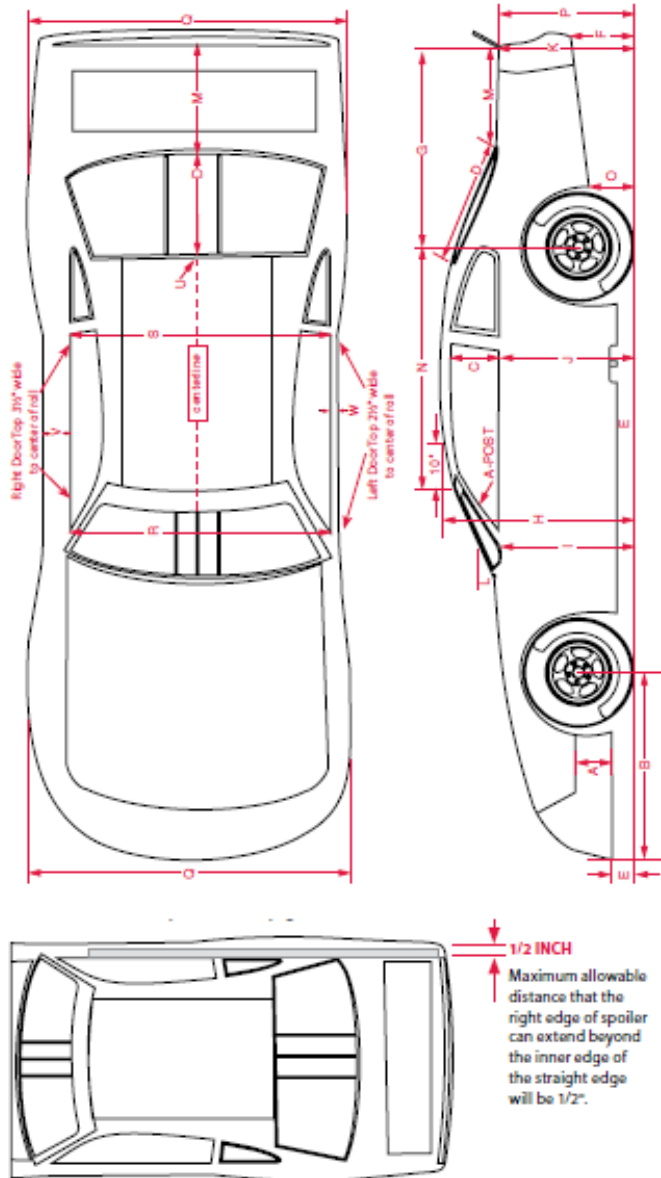

A	NOSE FLAP HEIGHT: from bottom of nose to top of side flap***	13"
B	FRONT OVERHANG (MAX): on centerline	46"
C	SIDE WINDOW OPENING (MIN): at B-post	15"
D	REAR WINDOW LENGTH: on centerline** Five Star bodies AR bodies	31½" 31¼"
E	NOSE/SIDE PANEL CLEARANCE (MIN): from ground	4"
F	BUMPER COVER HEIGHT (MAX): from ground	15"
G	REAR OVERHANG (MAX): from base of spoiler at centerline to axle centerline	47"
H	ROOF HEIGHT (MIN): 10" back from windshield, on centerline	47"
I	FENDER HEIGHT: at rear	32½"
J	DOOR HEIGHT (MIN): at rear	33"
K	QUARTER PANEL HEIGHT: at bumper cover/deck lid intersection (+/-¼")	34½"
L	WINDSHIELD ANGLE: at center/at roof windshield post	26/30°
M	REAR DECK LENGTH (MAX): at center, from base of spoiler to rear window** Five Star bodies AR bodies	23¼" 23¾"
N	FRONT OF ROOF TO CENTER OF REAR AXLE	57½"
O	QUARTER PANEL HEIGHT: at back of wheel well opening	13"
P	BUMPER COVER HEIGHT: at base of spoiler, on centerline	34¼"
Q	BODY WIDTH (MAX): at wheel wells	79½"
R	DOOR TO DOOR WIDTH (measured through car): at A-posts and inside edges of doors	68"
S	DOOR TO DOOR WIDTH (measured through car): at B-posts and inside edges of doors	67"
U	ROOF HEIGHT, REAR: at centerline	45½"
V	RIGHT DOOR TOP: to center of roll	3½"
W	LEFT DOOR TOP: to center of roll	2½"

\* If Dimensions H, I, J, K or P are higher than the stated dimensions, all five must increase by the same amount.

\*\* Must fit centerline template within allowable tolerance.

\*\*\* 13 inches is the height of the nose flap only. This dimension is not measured from